



MX1500XTS

Programmable Hi-Power Blender with Sound Enclosure and 64 oz. Stainless Steel Container



*Made in USA with US and foreign parts.

MAIN FEATURES

- Heavy-duty, 3.5 peak HP, high-performance motor
- Power through the toughest ice and frozen fruit mixtures in seconds
- 45,000 RPM bare motor speed
- Super-high speed for the smoothest consistencies, with 2-speed selection
- 4 reprogrammable beverage stations for perfect results every time
 - Factory-set programs for the most popular beverage types
 - Easy to create your own customized programs—fully reprogrammable directly on the keyboard! No need for a USB or computer for programming
- Variable speed and time selections for maximum control over consistencies
- Daily and total drink counter display
- Easy-to-clean, electronic-membrane keypad
- Sound enclosure included for serious noise reduction
- 64 oz. stainless-steel container
 - High-performance, cloverleaf jar design creates a high-power vortex, funneling food directly into the blade
 - Unbreakable, dishwasher-safe, stainless steel construction
- High-performance, high-impact, stainless steel blade
 - Easily user replaceable for servicing
- Metal-on-metal, stainless steel coupling system for durability and reliability—both couplings are user replaceable
- Easily removable container cover with removable clear cap for adding ingredients and for pressure reduction during hot food blending
- One-piece, dishwasher-safe, removable jar pad
- Recommended for 75+ drinks per day
- Limited Three-Year Motor Warranty and Two-Year Parts & Labor Warranty

ELECTRICAL

Voltage: 120

Frequency: 60Hz

Watts: 1500

Amps: 12.5

Plug Type: A

Cord Length: 6 feet



SALES FEATURES

Get smooth, consistent results every time with the Waring® MX1500XTS. This heavy-duty, 3.5 HP blender teams up with The Raptor® stainless steel jar and blade assembly for maximum power and efficiency. The rock-solid base features an easy-to-clean, electronic-membrane keypad with blue backlit LCD screen and four programmable beverage stations. Perfect for a busy bar, health facility, school or coffee shop.

Programmable Hi-Power Blender with Sound Enclosure and 64 oz. Stainless Steel Container

MX1500XTS



@waringcommercial

©2019 Waring Commercial
314 Ella T. Grasso Avenue, Torrington, CT 06790
Tel. 800-492-7464 • Fax 860-496-9008

waringcommercialproducts.com



Programmable Hi-Power Blender with Sound Enclosure and 64 oz. Stainless Steel Container MX1500XTS

PARTS & ACCESSORIES

- | | | | |
|---|--|---|--|
|  | CAC90
64 oz. Stainless Steel Container |  | CAC95-12
64 oz. Green Copolyester Container |
|  | CAC93X
48 oz. Copolyester Container |  | CAC95-28
64 oz. Orange Copolyester Container |
|  | CAC93X-03
48 oz. Yellow Copolyester Container |  | CAC116
Blending Assembly Kit and Retainer Ring Kit |
|  | CAC93X-06
48 oz. Blue Copolyester Container |  | CAC119
Retainer Ring Wrench |
|  | CAC93X-10
48 oz. Purple Copolyester Container |  | CAC158
Blending Assembly Kit |
|  | CAC93X-12
48 oz. Green Copolyester Container |  | CAC159
Retainer Ring Kit |
|  | CAC93X-28
48 oz. Orange Copolyester Container |  | CAC160
Drive Coupling |
|  | CAC95
The Raptor® – Aggressive, All-Purpose, Stackable, 64 oz., BPA-Free Copolyester Container |  | CAC161
Drive Coupling Removal Tool |
|  | CAC95-03
64 oz. Yellow Copolyester Container |  | CAC169
Spatula – Custom designed for use with MX Series Blenders |
|  | CAC95-06
64 oz. Blue Copolyester Container |  | SE1000
Large Sound Enclosure |
|  | CAC95-10
64 oz. Purple Copolyester Container |  | SE500
Small Sound Enclosure |

DIMENSIONS

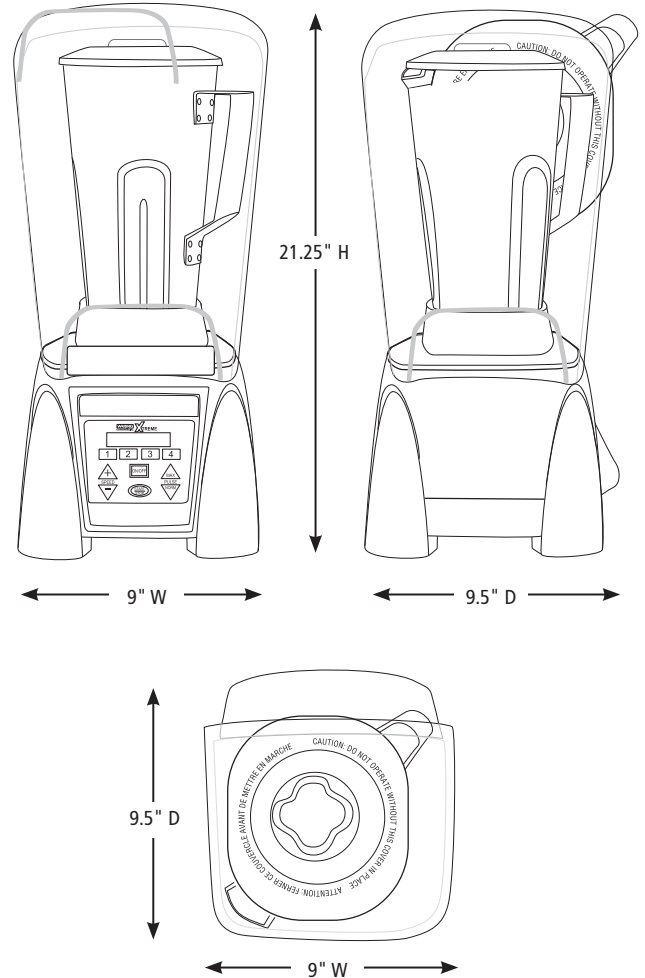

Out of Box Weight: 16.66 lb.

ORDERING INFORMATION	#STD. PKG.	GIFTBOX WEIGHT	CUBIC FEET	BOX DIMENSIONS D X W X H	UPC	CASE PKG.	MC WEIGHT	MC DIMENSIONS D X W X H	MBC
MX1500XTS – Programmable Hi-Power Blender with Sound Enclosure, 64 oz. Stainless Steel Container	1	25	2.23	20.25" x 11.125" x 16.375"	040072006784	1	27	20.875" x 11.625" x 17.75"	10040072006781



@waringcommercial

©2019 Waring Commercial
314 Ella T. Grasso Avenue, Torrington, CT 06790
Tel. 800-492-7464 • Fax 860-496-9008

waringcommercialproducts.com

19WC063876 / REV 09/19